



MURANG'A UNIVERSITY COLLEGE

A Constituent College of Jomo Kenyatta University of Agriculture and Technology

School of Pure and Applied Science

SUPPLEMENTALLY EXAMINATION

BUILDING DEPARTMENT

SEB 1241, ENGINEERING MATHEMATICS IV

DATE: 27TH JUNE 2016

TIME 2HRS

Instructions: Answer question **one** and any other **two**

QUESTION ONE:

- i) Integrate the function: $y = x^2\sqrt{(x^3 + 5)}$ (5 marks)
- ii) If $x = a \sin \theta$, $y = b \cos \theta$, find the area between $\theta = 0$ and $\theta = \pi$ (5 marks)
- iii) Find the mean value of the function:
 $y = 3x^2 + 4x + 1$ between $x = -1$ and $x = 2$ (5 marks)
- iv) Find the volume generated when the plane figure bounded by $y = 5 \cos 2x$, the x -axis and ordinates at $x = 0$ and $x = \frac{\pi}{4}$, rotates about the axis through a complete revolution. (5 marks)
- v) Find the position of the centre of gravity of solid formed when the plane figure bounded by the curve $x^2 + y^2 = 16$, the x -axis and the ordinates $x = 1$ and $x = 3$, rotates about the x -axis. (5 marks)
- vi) Find the area under the curve:

QUESTION TWO:

- a) Find the area generated when the arc of the parabola $y^2 = 8x$ between $x = 0$ and $x = 2$, rotates about the x-axis. (10 marks)
- b) Find the surface area generated when the arc of the curve $y = 3t^2$, $x = 3t - t^3$ between $t = 0$ and $t = 1$, rotates about OX through 2π radians. (10 marks)

QUESTION THREE:

- a) Find: I (moment of inertial) and the value of K for a rectangular plate $20\text{cm} \times 10\text{cm}$, of mass 2kg about an axis 5cm from one 20cm side as:

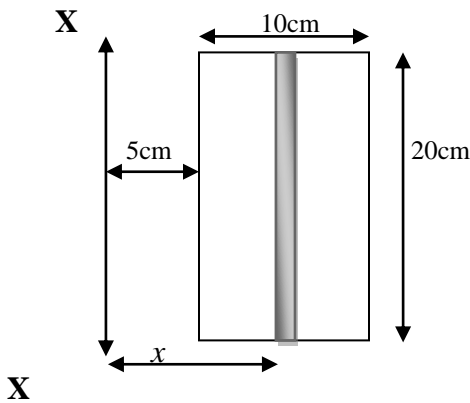

I = moment of inertial (or second moment of mass)
 K =radius of gyration about the given axis

- b) A metal door, $40\text{cm} \times 60\text{cm}$, has a mass of 8kg and is hinged along one 60cm side. Calculate:
- i) I about XX , the axis through the centre of gravity.
- ii) I about the line of hinge, AB .
- iii) K about AB . (6 marks)
- c) Find the radius of gyration of a metal disc of radius 6cm and total mass 0.5kg . (4 marks)

QUESTION FOUR:

- a) Integrate: $\int_0^1 x^2 \sqrt{x^2 + 1} \text{ w. r. } x$ (5 marks)
- b) Find: $\int \frac{\ln x}{x} dx$ (5 marks)
- c) Find: $\int x^4 \ln x dx$ (5 marks)
- d) Integrate: $\frac{2x}{\int(x^2+1)} dx$ (5 marks)

QUESTION FIVE:

- a) Integrate: $\sqrt{1-x^2}$ w.r.t x by using the substitution $x \equiv \sin \theta$ (6 marks)
- b) Evaluate: $\int_0^1 x e^x dx$
- c) Find: $\int \sin^5 \theta d\theta$ (4 marks)
- d) Find: $\int \cos x (\sin x)^3 dx$ (5 marks)