



MURANG'A UNIVERSITY OF TECHNOLOGY

SCHOOL OF ENGINEERING AND TECHNOLOGY

DEPARTMENT OF ELECTRICAL AND ELECTRONICSENGINEERING

UNIVERSITY ORDINARY EXAMINATION

2020/2021 ACADEMIC YEAR

**SECOND YEAR SECOND SEMESTER EXAMINATION FOR, DIPLOMA IN
ELECTRICAL AND ELECTRONICS**

EEE 062– MICRPROPROCESSORS

DURATION: 2 HOURS

Instructions to candidates:

1. Answer question One and Any Other Two questions.
2. Mobile phones are not allowed in the examination room.
3. You are not allowed to write on this examination question paper.

SECTION A: ANSWER ALL QUESTIONS IN THIS SECTION

QUESTION ONE (30 MARKS)

- (a) State two features of the following types of computers (4 marks)
- i mainframe.
 - ii Microframe
- (b) State any two internal components of a microprocessor unit and their functions. (4 marks)
- c) A 16k x 8-bits memory is implemented using 4kx4 memory chips. Determine the number of 4kx4 memory chips required. (4 marks)
- d) State any two advantages of assembly language programming over high level language programming. (2 marks)
- e) Describe the following stack instructions. (4 marks)
- i. Push.
 - ii. Pop.
- f) Represent the octal numbers of 746.35_8 in (6 marks)
- i. Binary.
 - ii. Hexadecimal.
 - iii. Decimal.
- a) The table below shows an 8085-program segment. For each instruction, state the: (6 marks)
- i. Addressing mode.
 - ii. Size of the machine code in bites.

LX1SP, 400H
LDAXB
MOV A, B

SECTION B – ANSWER ANY TWO QUESTIONS IN THIS SECTION

QUESTION TWO (20 MARKS)

- a) Define the following terms with respect to memories (3 marks)
- i. Access time.
 - ii. Non-volatile.
 - iii. Sequential.

- iv.
- b) A 32k x 8 RAM chip is decoded using a single decoder.
 - i. Determine the size of the decoder and the number of a AND gates required for decoding each address.
 - ii. Draw the schematic block of the RAM chip organization. (11 marks)
- c) A double-sided disk has 85-tracks per side, 20 sectors per track and 512 bytes/sector. 1694 sectors are available for user programs while the remainder is reserved for system use. Determine the:
 - i. Disk capacity in kilobytes.
 - ii. Amount of memory in kilobytes reserved for system use. (6 marks)

QUESTION THREE (20 MARKS)

- a) i) Define each of the following with respect to memory devices.
 - I. Serial access.
 - II. Volatile.
- ii) List the following memory types in descending order of access time: magnetic disk, flash memory, bipolar semiconductor, magnetic tape. (4 marks)
- b) Draw a labelled block diagram of a microprocessor unit and state the function of each part of the block. (8 marks)
- c) Describe the function of four types of pins found in a microprocessor. (8 marks)

QUESTION FOUR (20 MARKS)

- a) i) State the functions of each of the following input/output (I/O) port registers (3 marks)
 - I. Command.
 - II. Status.
 - III. Data.
- ii) State two advantages of memory mapped (I/O) port implementation over I/O mapped port implementation. (2marks)

b) i) Define each of the following with respect to digital-to-analog converter (DACs)

- I. Resolution.
- II. Range of operation.

ii) The figure below shows a circuit diagram of a DAC. Determine the output voltage, V_o

- I. All switches are closed.
- II. Only switch S_1 is closed.

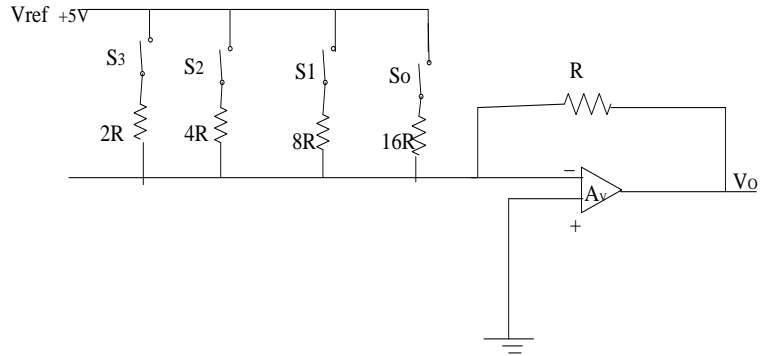

Figure 1

iii) State two fig.1 disadvantages of the DAC of the figure 1 above over an R/2R ladder-DAC.

(9 marks)

c) Figure 2 shows a logic circuit diagram of an I/O decoder.

- i. State with reasons whether the port is I/O mapped or memory mapped.
- ii. Determine the range of addresses assigned to I/O port.

(6 marks)

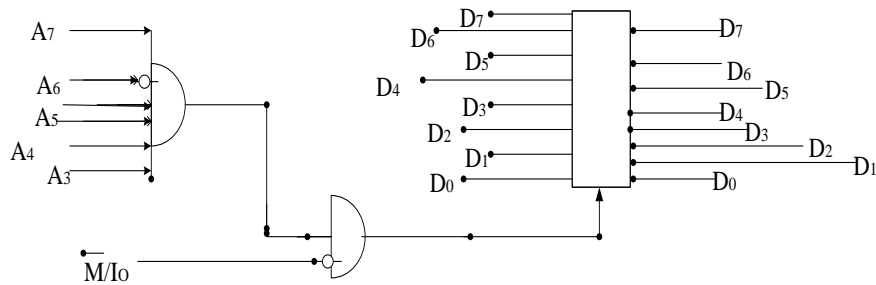

Figure 2